

Acme[®]

EYEFASH 2

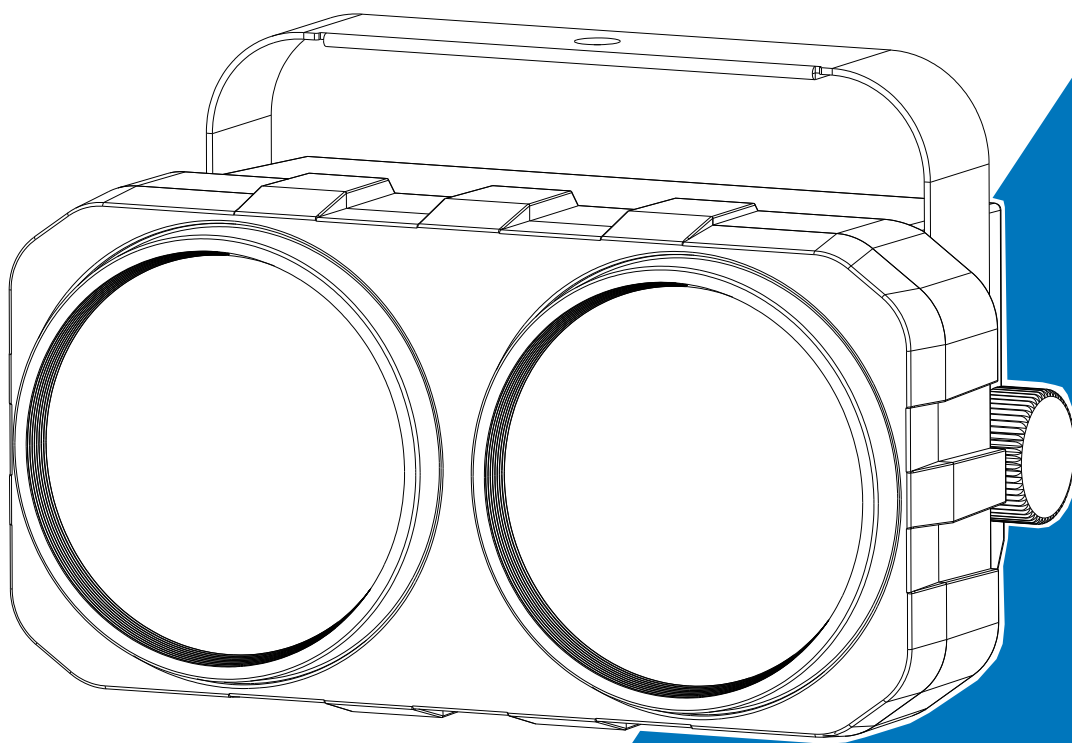

User Manual

Please read the instruction carefully before use

CONTENTS

01/ Safety Instructions.....	2
02/ Technical Specifications	4
03/ Control Panel.....	5
04/ How To Set The Unit.....	6
4.1 Main Functions	6
05/ Control By Universal DMX Controller	14
5.1 DMX512 Connection.....	14
5.2 Address Setting.....	15
5.3 DMX512 Configuration	15
06/ Error Information	18
07/ Troubleshooting	19
08/ Fixture Cleaning.....	19

01/ Safety Instructions



Please read the instruction carefully which includes important information about the installation, usage and maintenance.

WARNING

Please keep this User Guide for future consultation. If you sell the unit to another user, be sure that they also receive this instruction manual.

Important:

Damages caused by the disregard of this user manual are not subject to warranty. The dealer will not accept liability for any resulting defects or problems.

- Unpack and check carefully to ensure that there is no transportation damage before using the unit.
- This product is for indoor use only. Use only in a dry location.
- DO install and operate by qualified operator.
- DO NOT allow children to operate the fixture.
- Use safety chain when fixing the unit. Handle the unit by carrying its base instead of head only.
- The unit must be installed in a location with adequate ventilation, at least 50cm from adjacent surfaces.
- Be sure that no ventilation slots is blocked, otherwise the unit will be overheated.
- Before operation, ensure that you are connecting this product to the proper voltage in accordance with the specifications in this manual or on the product's specification label.
- It's important to ground the yellow/green conductor to earth in order to avoid electric shock.
- Minimum ambient temperature TA: 0°C. Maximum ambient temperature TA: 40°C. Do not operate this product at a lower or higher temperature.
- DO NOT connect the device to any dimmer pack.
- Keep flammable materials away from the fixture while operating to avoid fire hazard.
- Make sure the power cord is not crimped or damaged; replace it immediately if damaged.
- Unit's surface temperature may reach up to 50°C. DO NOT touch the housing bare-handed during its operation.
- Avoid any flammable liquids, water or metal from entering the unit. Once it happens, cut

off the mains power immediately.

- DO NOT operate in a dirty or dusty environment. DO clean the fixture regularly.
- DO NOT touch any wire during operation as there might be a hazard of electric shock.
- Avoid entanglement of the power cord with other wires.
- The minimum distance to objects/surface must be more than 0.5 meters.
- In the event of serious operating problem, stop using the unit immediately.
- Never turn on and off the unit time after time.
- The housing, the lenses, or the ultraviolet filter must be replaced if they are visibly damaged.
- DO NOT open the housing as there are no user serviceable parts inside.
- DO NOT attempt to operate this unit if it becomes damaged. DO NOT attempt any repairs yourself. Repairs carried out by unskilled people can lead to damage or malfunction. Please contact the nearest authorized technical assistance center if needed.
- Disconnect this product from its power source before servicing.
- DO use the original packaging if the device is to be transported.
- Avoid direct eye exposure to the light source while the product is on.
- DO NOT operate this product if you see damage on the housing, shields, or cables. Have the damaged parts replaced by an authorized technician at once.

Installation:

- ▶ DO install and operate by qualified operator. Fixture(s) should be installed in areas outside walking paths, seating areas, or away from areas where unauthorized personnel might reach the fixture by hand. NEVER stand directly below the fixture(s) when rigging, removing or servicing.
- ▶ Always ensure that the unit is firmly fixed to avoid vibration and slipping off during operation. Ensure that the trussing or area of installation must be able to hold 10 times the weight without any deformation. Always attach a safety cable that can hold at least 12 times the weight of the fixture whenever installing this fixture in a suspended environment to ensure that the fixture will not fall if the clamp fails.

02/ Technical Specifications

Power Voltage	100-240V~ 50/60Hz	
Power Consumption	215W	
Light Source	2x100W COB LED	
Beam Angle	39.5°	
Dimmer/Strobe	0-100% smooth dimming; outstanding strobe effect with variable speed	
Control	DMX Channel	1/2/4/6 Channels
	Control Mode	DMX512
		RDM
	Firmware Upgrade	Firmware Upgrade via DMX link
Construction	Display	OLED display
	Data In/Out	3-pin XLR (5-pin XLR is optional)
	Power In/Out	Power Connector in/out
	Protection Rating	IP20
Features	2 x WW LEDs with individual control	
	Unique tungsten effect	
Dimensions	305x154x192mm	12"x6.1"x7.6" in
Weight	2.6kgs	5.7lbs

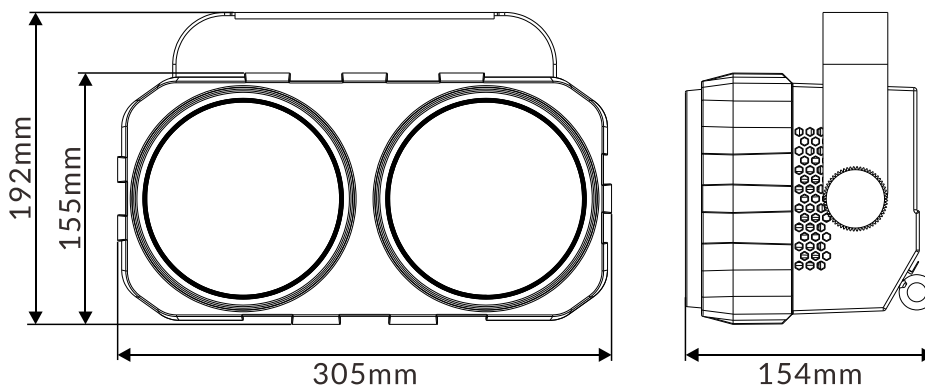

Photometric Diagram:

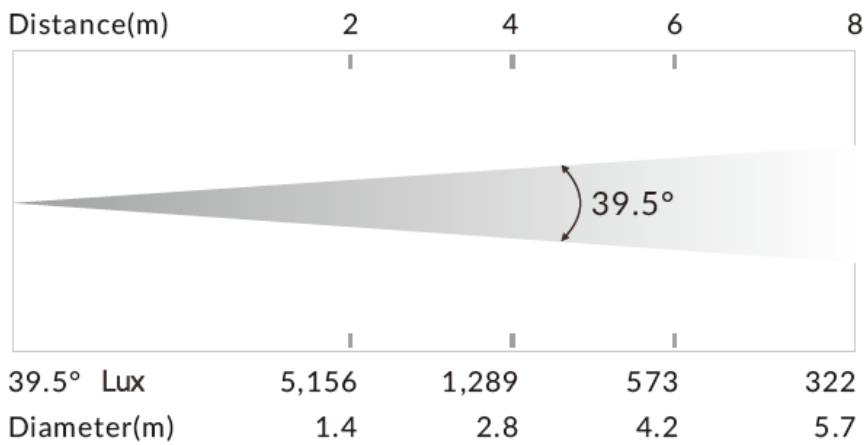

03/ Control Panel

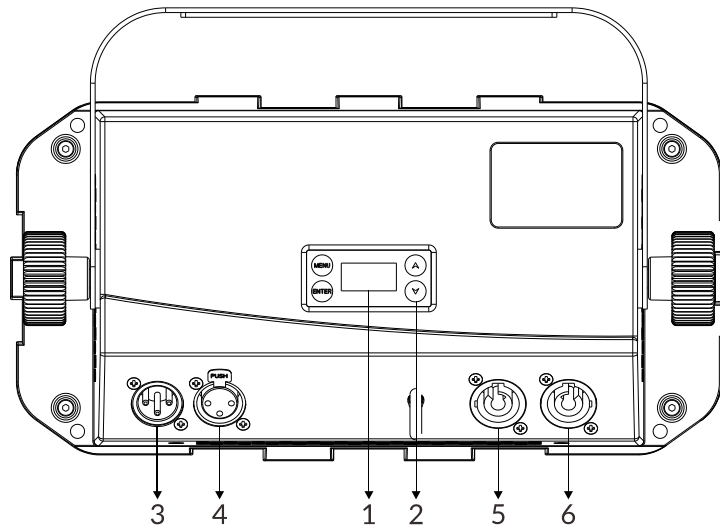

1. Display	To show the various menus and the selected function	
2. Buttons	MENU	To enter into move backward or leave the menu
	▲ UP	To go backward to move up in the menu
	▼ DOWN	To go forward to move down in the menu
	ENTER	To perform the desired functions
3. DMX IN	For DMX512 link, use 3-pin XLR cable to link the unit and DMX controller to input DMX signal (5-pin XLR cable is optional)	
4. DMX OUT	For DMX512 link, use 3-pin XLR cable to link the next units to output DMX signal (5-pin XLR cable is optional)	
5. POWER IN	To connect to supply power	
6. POWER OUT	To connect to the next fixture	

04/ How To Set The Unit

4.1 Main Functions

- ▶ To access the control menus, press the [MENU] button.
- ▶ Navigate the menu structure, using the [ENTER], [▲ UP] and [▼ DOWN] buttons.
- ▶ To select a menu option or to confirm a selection, press the [ENTER] button.
- ▶ To return to a higher level in the menu structure without making a change, press the [MENU] button, or wait 30 seconds.

The main functions are shown below:

MENU	SUBMENU	OPTIONS
DMX Settings	DMX Address	1-512 (Default=1)
	Channel Mode	1 CH
		2 CH
		4 CH
		6 CH
	DMX Last State	Blackout
		Hold
Manual		
Fixture Settings	Dimmer Curve	Linear
		Square Law
		Inv SQ Law
		S Curve
	Dimmer Speed	Fast
		Smooth
UND		
Display Settings	Display Invert	Off
		On
	Temperature Unit	°C
		°F
	Language	English
	Chinese	
Auto Test		
Manual Test	Dimmer	0-255
	Strobe	0-255

MENU	SUBMENU	OPTIONS		
Information	Fixture Use Hour			
	LED Use Hour	Total LED Hour		
		LED On Hour		
		LED Hours Reset	Password=050	
	Temperature		Current	Max temp
		LED 1		
		LED 2		
	Fan State			
	Firmware Version			
	RDM UID			
Error Logs	Fixture Errors			
	Reset Error Log	Password=050		
Factory Restore	No			
	Yes			

DMX Settings

Enter the control menu and select **DMX Settings**, press ENTER. Use the UP/DOWN button to select **DMX Address**, **Channel Mode** or **DMX Last State**.

DMX Address

Select **DMX Address**, press ENTER.

Use UP/DOWN button to select an address, confirm your selection with ENTER.

CHANNEL MODE	DMX ADDRESS
1 CH	1-512
2 CH	1-511
4 CH	1-509
6 CH	1-507

To exit the menu, press MENU, or wait 30 seconds.

Channel Mode

Select **Channel Mode**, press ENTER.

Use UP/DOWN button to select between **1 CH**, **2 CH**, **4 CH** and **6 CH**, confirm your selection with ENTER.

To exit the menu, press MENU, or wait 30 seconds.

DMX Last State

Select **DMX Last State**, press ENTER.

Use UP/DOWN button to select one of the following status:

Blackout (Fixture blacks out if DMX signal stops)

Hold (The device continues to operate in the current mode with the last active DMX values until the signal returns)

Manual (The device accepts the DMX value stored in the 'Manual Test' menu)

Confirm your selection with ENTER.

To exit the menu, press MENU, or wait 30 seconds.

Fixture Settings

Enter the control menu and select **Fixture Settings**, press ENTER. Use the UP/DOWN button to select **Dimmer Curve** or **Dimmer Speed**.

Dimmer Curve

Select **Dimmer Curve**, press ENTER.

Use UP/DOWN button to select **Linear**, **Square Law**, **Inv SQ Law** or **S Curve**, confirm your selection with ENTER.

Dimmer Modes

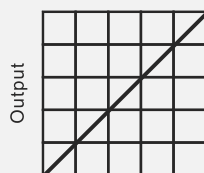

Optically Linear

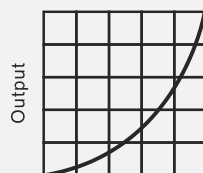

Square Law

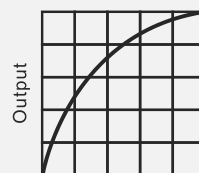

Inverse Square Law

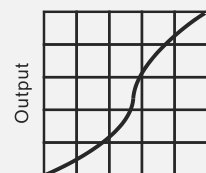

S-curve

To exit the menu, press MENU, or wait 30 seconds.

Dimmer Speed

Select **Dimmer Speed**, press ENTER.

Use UP/DOWN button to select **Fast**, **Smooth** or **UND**, confirm your selection with ENTER.

To exit the menu, press MENU, or wait 30 seconds.

Display Settings

Enter the control menu and select **Display Settings**, press ENTER. Use the UP/DOWN button to select **Display Invert**, **Temperature Unit** or **Language**.

Display Invert

Select **Display Invert**, press ENTER.

Use UP/DOWN button to select **Off** (display normal) or **On** (display inverted), confirm your selection with ENTER.

To exit the menu, press MENU, or wait 30 seconds.

Temperature Unit

Select **Temperature Unit**, press ENTER.

Use UP/DOWN button to select **°C** or **°F**, confirm your selection with ENTER.

To exit the menu, press MENU, or wait 30 seconds.

Language

Select **Language**, press ENTER.

Use UP/DOWN button to select **English** or **Chinese**, confirm your selection with ENTER.

To exit the menu, press MENU, or wait 30 seconds.

Auto Test

Select **Auto Test**, press ENTER.

The device immediately performs an automatic self-test.

To end the automatic self-test and exit the menu, press MENU, or wait 30 seconds.

Manual Test

Select **Manual Test**, press ENTER.

Use UP/DOWN button to select **Dimmer** or **Strobe**, confirm your selection with ENTER.

Use UP/DOWN button to select a value between **0** and **255**, confirm your selection with ENTER.

To exit the menu, press MENU, or wait 30 seconds.

(The device returns to its original DMX state after the manual test. The test values are saved automatically when the device is switched off.)

Information

Enter the control menu and select **Information**, press ENTER. Use the UP/DOWN button to select **Fixture Use Hour**, **LED Use Hour**, **Temperature**, **Fan State**, **Firmware Version**, **RDM UID** or **Error Logs**.

Fixture Use Hour

Select **Fixture Use Hour**, press ENTER.

The operating hours is displayed.

To exit the menu, press MENU, or wait 30 seconds.

LED Use Hour

Select **LED Use Hour**, press ENTER.

Use UP/DOWN button to select **Total LED Hour** (total time) or **LED On Hour** (current switch-on time), confirm your selection with ENTER.

The total time or current switch-on time is displayed.

Use UP/DOWN button to select **LED Hours Reset**, confirm your selection with ENTER.

Use UP/DOWN button to set the password 050, confirm your selection with ENTER. The LED operating hours is reset.

To exit the menu, press MENU, or wait 30 seconds.

Temperature

Select **Temperature**, press ENTER.

The device temperature is displayed.

To exit the menu, press MENU, or wait 30 seconds.

Fan State

Select **Fan State**, press ENTER.

The fan status is displayed.

To exit the menu, press MENU, or wait 30 seconds.

Firmware Version

Select **Firmware Version**, press ENTER.

The firmware version is displayed.

To exit the menu, press MENU, or wait 30 seconds.

RDM UID

Select **RDM UID**, press ENTER.

The RDM UID is displayed.

To exit the menu, press MENU, or wait 30 seconds.

Error Logs

Select **Error Logs**, press ENTER.

Use UP/DOWN button to select **Fixture Errors**, confirm your selection with ENTER.

The error list is displayed.

Use UP/DOWN button to select **Reset Error Log**, confirm your selection with ENTER.

Use UP/DOWN button to set the password 050, confirm your selection with ENTER. The relevant error logs are reset.

To exit the menu, press MENU, or wait 30 seconds.

Factory Restore

Select **Factory Restore**, press ENTER.

If you wish to reset the device to the factory settings, select **Yes**. If you do not wish to reset anything, select **No**. Confirm your selection with ENTER.

To exit the menu, press MENU, or wait 30 seconds.

RDM functions: Certain menus of the device and functions can be called up via the RDM protocol.

The parameter IDs are implemented as follows for different commands:

Parameter ID	Command 'Discovery'	Command 'Set'	Command 'Get'
DISC_UNIQUE_BRANCH	✓		
DISC_MUTE	✓		
DISC_UN_MUTE	✓		
DEVICE_INFO			✓
SUPPORTED_PARAMETERS			✓
SOFTWARE_VERSION_LABEL			✓
DMX_START_ADDRESS		✓	✓
IDENTIFY_DEVICE		✓	✓
DEVICE_MODEL_DESCRIPTION			✓
PARAMETER_DESCRIPTION			✓
MANUFACTURER_LABEL			✓
DEVICE_LABEL		✓	✓
BOOT_SOFTWARE_VERSION_ID			✓
BOOT_SOFTWARE_VERSION_LABEL			✓
DMX_PERSONALITY		✓	✓
DMX_PERSONALITY_DESCRIPTION			✓
SLOT_INFO			✓
SLOT_DESCRIPTION			✓
SENSOR_DEFINITION			✓
SENSOR_VALUE			✓
DEVICE_HOURS			✓
RESET_DEVICE		✓	

✓ -Command implemented for the respective parameter ID

05/ Control By Universal DMX Controller

5.1 DMX512 Connection

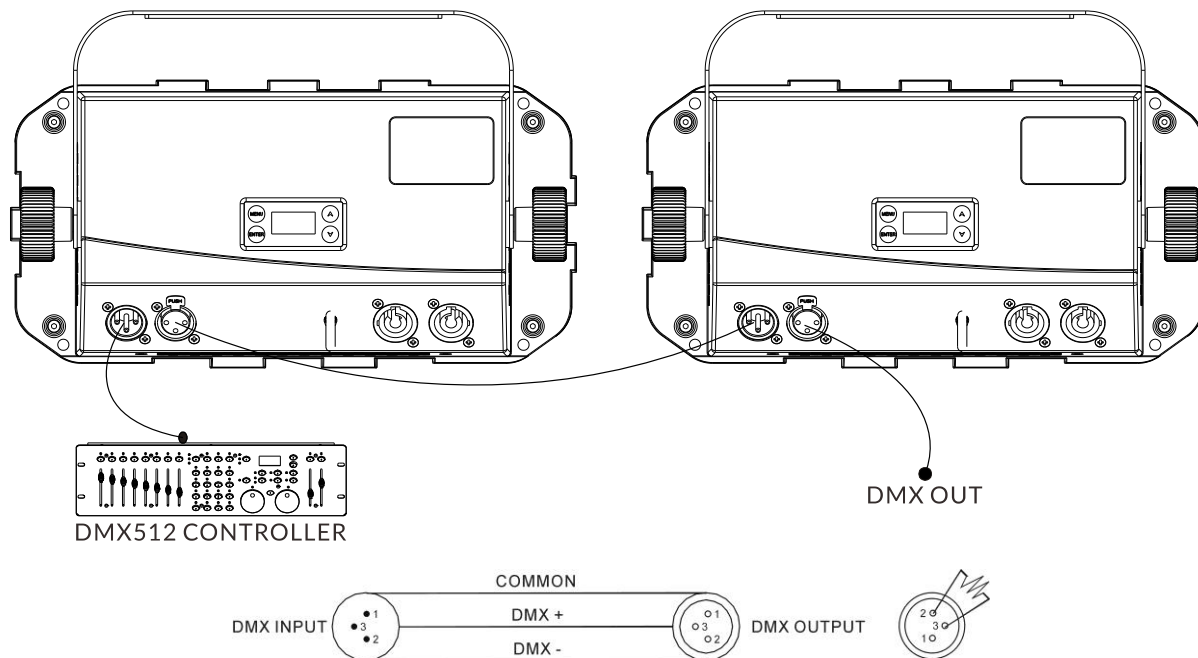

1. At last unit, the DMX cable has to be terminated with a terminator. Solder a 120-ohm 1/4W resistor between pin 2(DMX-) and pin 3(DMX+) into a 3-pin XLR-plug and plug it in the DMX-output of the last unit.
2. Connect the unit together in a “daisy chain” by XLR plug cable from the output of the unit to the input of the next unit. The cable can only be used in series and cannot be connected in parallel. DMX 512 is a very high-speed signal. Inadequate or damaged cables, soldered joints or corroded connectors can easily distort the signal and shut down the system.
3. The DMX output and input connectors are pass-through to maintain the DMX circuit, when one of the units' power is disconnected.
4. Each lighting unit needs to have a DMX address to receive the data by the controller. The address number is between 1-512.
5. The end of the DMX 512 system should be terminated to reduce signal errors.
6. 3 pin XLR connectors are more popular than 5 pins XLR.
 - 3 pin XLR: Pin 1: GND, Pin 2: Negative signal (-), Pin 3: Positive signal (+)
 - 5 pin XLR: Pin 1: GND, Pin 2: Negative signal (-), Pin 3: Positive signal (+), Pin4, Pin5 not used.

5.2 Address Setting

If you use a universal DMX controller to control the units, you have to set DMX address between 1 and 512 so that the units can receive DMX signal.

Press the MENU button to access the control menus, select DMX Settings, press the ENTER button to confirm. Use the UP/DOWN button to select DMX Address, press the ENTER button to confirm, the present address will show on the display. Use the UP/DOWN button to adjust the address between 001 and 512, press the ENTER button to store. To exit the menu, press MENU, or wait 30 seconds.

Please refer to the following diagram to address your DMX512 channel for the first 4 units.

Channel Mode	Unit 1 Address	Unit 2 Address	Unit 3 Address	Unit 4 Address
1 channels	1	2	3	4
2 channels	1	3	5	7
4 channels	1	5	9	13
6 channels	1	7	13	19

5.3 DMX512 Configuration

Please control the fixture by referring to the configurations below.



Attentions:

- ▶ The unit will maintain the last condition until reset if you cut-off the DMX signal.
- ▶ For the channel Function, keep the value for about 3 seconds, then the corresponding function will take into effect.



1 Channels (Mode 1):

CHANNEL	VALUE	FUNCTION
1	000-255	 DIMMER 0%→100%





2 Channels (Mode 2):

CHANNEL	VALUE	FUNCTION
1	000-255	 DIMMER 0%→100%
2	000-255	 DIMMER 0%→100%

4 Channels (Mode 3):

CHANNEL	VALUE	FUNCTION
1	000-255	 DIMMER 0%→100%
2	000-255	 DIMMER 0%→100%
3	000-255	 DIMMER 0%→100%
4	000-005 006-123 124-127 128-185 186-190 191-249 250-255	STROBE Open Flash Rate, Slow to Fast Open 2 LEDs Random Strobe at the same time Open 2 LEDs Random Strobe respectively Open

6 Channels (Mode 4):

CHANNEL	VALUE	FUNCTION
1	000-255	 DIMMER 0%→100%
2	000-255	 DIMMER FINE 0%→100%
3	000-255	 DIMMER 0%→100%
4	000-255	 DIMMER FINE 0%→100%
5	000-255	 DIMMER 0%→100%
6	000-005 006-123 124-127 128-185 186-190 191-249 250-255	STROBE Open Flash Rate, Slow to Fast Open 2 LEDs Random Strobe at the same time Open 2 LEDs Random Strobe respectively Open

06/ Error Information

Error codes are shown continuously in the display when the fixture fails and they will not disappear until the fixture is repaired.

Fan Error

- Check whether the fan is not running.
- Check whether the fan leads are installed in place or disconnected.
- Check whether the fan is damaged.
- Check whether there are obstacles in the fan operating range.
- Check whether the fan circuit on the motherboard breaks down.
- Check whether the component is damaged.
- Check whether the fan is out of order.

Temp. Error

- Check whether the temperature detecting board is normal.
- Check whether the components of the temperature detecting board are damaged.
- Check whether the lead on the temperature detecting board is installed in place or disconnected.

07/ Troubleshooting

Following are a few common problems that may occur during operation. Here are some suggestions for troubleshooting:

A. The unit does not work, no light and the fan does not work

- ▶ Check the connected power.
- ▶ Measure the voltage.
- ▶ Check the power indicator to see whether it can be lit up or not.

B. Not responding to the DMX controller

- ▶ Check whether the DMX connectors and the DMX cables are connected correctly.
- ▶ Check whether the DMX address is correctly set.
- ▶ If the intermittent DMX signal problem occurs, check whether the XLR socket and the signal cable are well connected.
- ▶ Try it with another DMX controller.
- ▶ Check whether the DMX cables run near or alongside to the high-voltage cables, which may damage or interfere with the signal circuit.

08/ Fixture Cleaning

It is absolutely essential that the fixture is kept clean to ensure the maximum light-output and allow the fixture to function reliably throughout its life. The fixture must be cleaned regularly to avoid dust, dirt and smoke-fluid residues building up on or within the fixture. The cleaning frequency depends on the application environment. Clean the fixture immediately if the dust enters it to avoid damage to the optical lens due to excessive dust.

- ▶ A soft lint-free cloth moistened with any good glass cleaning fluid is recommended, under no circumstances should solvents be used.
- ▶ Always dry the parts carefully.
- ▶ Clean the external optical lens at least every 20 days.

Declaration of Conformity

We declare that our products (lighting equipments) comply with the following specification and bears CE mark in accordance with the provision of the Electromagnetic Compatibility (EMC) Directive 2014/30/EU.

EN 55032: 2015+A11: 2020; EN 55035: 2017+A11: 2020;
EN IEC 61000-3-2: 2019; EN 61000-3-3: 2013+A1: 2019.

&

Harmonized Standard

EN 60598-2-17: 2018;

EN 60598-1: 2015+A1: 2018.

Safety of household and similar electrical appliances
Part 1: General requirements and tests



www.acme.com.cn